

AIT1500N2K CLASS B AIS TRANSPONDER

Installation and instruction Manual



1. Introduction

Congratulations on the purchase of your AIT1500N2K Class B AIS Transponder. It is recommended that your transponder is installed by a professional installer.

-  **This Quick Start Guide will provide basic information on the AIT1500N2K to allow you to install and get the AIT1500N2K working. The full User Manual, that covers all of our transponder family of products, is available to download on the Support section of our website www.digitalyachtamerica.com**

2. Before you start

You will need the following items and tools to complete the installation:

- Class B AIS Transponder.
- Dedicated VHF/AIS antenna and cable (or splitter) – not supplied.
- Access to the NMEA2000 Network where the unit is to be installed and a spare T-Piece (connection point).
- Four M4 screws or other fixings appropriate to the mounting location.

To configure the unit you will need:

- A PC running Microsoft Windows XP® / Windows Vista® / Windows 7 or Mac OSX with a free USB port.
- proAIS2 Class B+ AIS Transponder configuration software – Windows and Mac versions of the software are available for download from our “Online CD” at <https://support.digitalyacht.net>
- An MMSI number for your vessel

Note: *You can obtain an MMSI (Maritime Mobile Service Identity) from the same authority that issues ship radio licences in your area. An MMSI may have already been provided with your existing VHF radio licence. The MMSI number used for the AIS Transponder should be the **same** as that programmed into your VHF DSC radio.*

-  *If you do not have an MMSI number the AIS Transponder will operate in receive only mode. **Do not enter an invalid MMSI number.***

3. Installation

Before starting installation select a suitable location for the AIS Class B Transponder. The unit is water resistant; however it should be installed below deck in a dry location. When locating the unit you should consider:

- Routing of power and VHF antenna cables to the unit.
- Provision of sufficient space around the unit for cable connections.
- Routing of the integral NMEA2000 cable to the boat’s NMEA2000 network (backbone).
- Maintaining the compass safe distance of 0.5m.
- Visibility of the front panel indicators.

Installation Step 1 – VHF/AIS Antenna or Splitter

- Install the VHF/AIS antenna (not supplied) according to the hand book instructions supplied with the antenna.
- If you are going to share the boat’s existing VHF antenna i.e. use the antenna for both the VHF and AIS, you will need to install a suitable antenna splitter. It is very important that this splitter is suitable for use with an AIS Transponder as some of the lower cost splitters only switch one input and are only suitable for use with an AIS receiver. We recommend our SPL2000 “Zero Loss” Technology splitter.
- The AIS antenna connector on the AIT1500N2K is a BNC type connector and it may be necessary to get a PL259 to BNC adaptor if you are connecting a normal VHF antenna to the AIT1500N2K as these are terminated in the standard PL259 VHF connector.



Installation Step 2 – Locating and Fixing the unit

- The AIT1500N2K has a high sensitivity GPS receiver with an internal antenna which is designed to be used below deck in GRP Fibreglass hulled boats. The GPS antenna is located in the top left corner of the unit behind the Digital Yacht Logo.
- The AIT1500N2K unit must be mounted on a vertical bulkhead so that the GPS antenna (top edge of AIT1500N2K) is pointing towards the sky. Care should be taken to ensure that only GRP fibreglass is between the GPS antenna and the sky, with no metallic or electrical objects above the antenna.
- Location of the AIT1500N2K is critical for good GPS reception and it is strongly recommended that before fixing the AIT1500N2K in the chosen location, that the GPS reception is checked.
- The supplied proAIS2 software for PC/Mac is ideal for this purpose. With the unit powered up (from the boat's NMEA2000 network) and connected via the USB cable to a PC/Mac running the proAIS2 software, view the "GNSS Status" page and ensure there is good GPS reception with the AIT1500N2K in the desired location.



Unit Dimensions

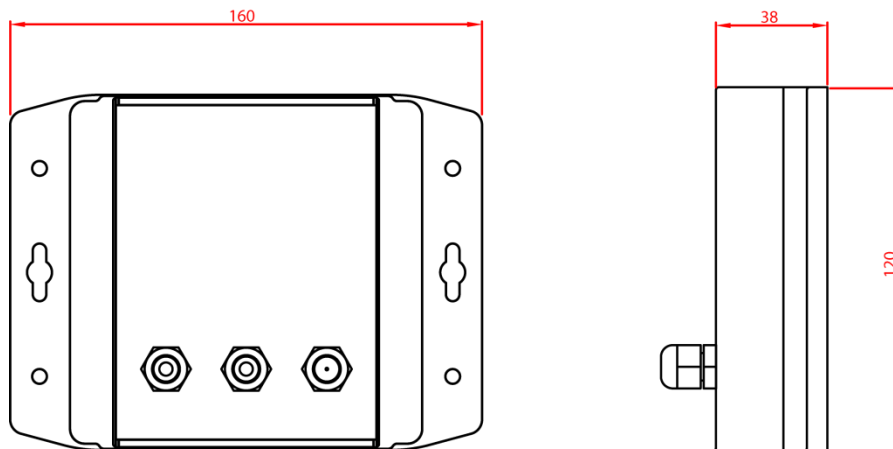

- Once you are confident that the AIT1500N2K is in the best location for good GPS reception, secure the AIS Transponder to a flat vertical surface in the selected location, using four M4 wood screws or other fixings suited to the material the unit is being fixed to.

Installation Step 3 – Connection to the NMEA2000 Network

- The AIT1500N2K will take its power from the NMEA2000 network, but before connecting the AIT1500N2K to the NMEA2000 network, make sure that the power to the NMEA2000 network is turned off.
- The AIT1500N2K has an integral 0.75m NMEA2000 cable terminated in a standard micro male NMEA2000 connector, that will plug straight in to a spare female "T Piece" on many NMEA2000 networks. On some "proprietary" NMEA2000 networks, a special adaptor cable will be required from the manufacturer.
 - Raymarine SeaTalkNG to NMEA2000 Adaptor Cable Part No A06045
 - Simrad Simnet to NMEA2000 Adaptor Cable Part No 24006199



Installation Step 4 – NMEA2000 Interfacing

- A table showing all of the NMEA2000 PGNs (messages) that the AIT1500N2K transmits on to the NMEA2000 network are shown below. Some chart plotters do not support all of these PGNs, so please contact the chart plotter manufacturer if not all AIS target types are being displayed.

PGN No.	PGN Title
129038	Class A Position Report
129039	Class B Position Report
129040	Class B Extended Position Report
129793	AIS UTC and Date report
129794	AIS Class A Static and Voyage Related Data
129800	AIS UTC/Date Inquiry
129801	AIS Address Safety Message
129802	AIS Broadcast Safety Message
129810	AIS Class B static data part B
129809	AIS Class B static data part A
129041	AtoN position report
129025	Position – rapid update
129026	COG/SOG – rapid update

Installation Step 5 – USB Interface

- When connected to a PC or MAC via the USB cable, the AIT1500N2K will only get enough power from the computer to power the microprocessor and the AIS receiver. This allows you to program the MMSI number and other static data at home or in the office prior to installation. The AIT1500N2K will not transmit or get a valid GPS position fix when only powered from the USB interface and the RED Status LED will always be lit when powered from the USB cable.
- If you need to extend the USB cable, please use a USB extension cable that is no more than 4m in length. The maximum length of USB cable without the use of a powered extender cable or Hub is 5m.
- Please do not plug in the USB cable of the AIT1500N2K to your PC until after you have installed the proAIS2 software, which also installs the USB drivers for the AIT1500N2K. Installing proAIS2 is covered in section 4 - Configuration.
- After the AIT1500N2K is configured, the USB connection can be used to provide data to navigation program running on a PC or Mac. Please note that only one navigation program at a time can receive data from the AIT1500N2K.
- The AIT1500N2K USB interface is not fully isolated and high levels of static or large differences in ground voltages between the PC supply and the boat's DC supply can damage the AIT1500N2K's USB interface. For maximum reliability, if you intend to permanently connect the AIT1500N2K to a computer, we recommend using an NMEA to USB adaptor connected to the AIT1500N2K's NMEA0183 output which provides an extra level of protection/isolation and can avoid costly damage to the AIT1500N2K.

Installation Step 6 – Power Up

- Turn on the power to the NMEA2000 network which the AIT1500N2K is connected to.
- Verify that the green LED illuminates for a short period and then all four LED indicators on the front of the unit flash once, followed by illumination of the amber and red LED's.
- Installation is now complete. The AIT1500N2K needs to be configured using the proAIS2 software – see next section.



4. Configuration

The AIT1500N2K transponder must be correctly configured for your vessel before operation. All configuration information must be entered carefully as this information will be transmitted to other AIS equipped vessels and shore stations.

The AIS transponder is configured by connecting to a PC or Mac running the 'proAIS2' configuration tool supplied. For the purposes of programming, the AIT1500N2K can take sufficient power from the USB cable to communicate with the computer but not to operate as a Class B+ Transponder which requires an external 12v or 24v DC supply.

- Visit our "Online CD" at <https://support.digitalyacht.net> and look for the proAIS2 software for Windows or Mac. Download the one applicable to your computer and either unzip and run the Setup.exe for Windows or install the proAIS2.dmg for Mac. During installation the USB drivers will be automatically installed.
- Plug in the AIT1500N2K USB cable in to your computer and then launch proAIS2. Select the COM port that the AIT1500N2K has been allocated by Windows or OSX. Click the 'Connect' button The computer will now query the AIT1500N2K and display any "Static" boat data stored in the unit. All new units will have no data stored and so you will just have a series of blank boxes in which you will need to enter your boat's data (see below).

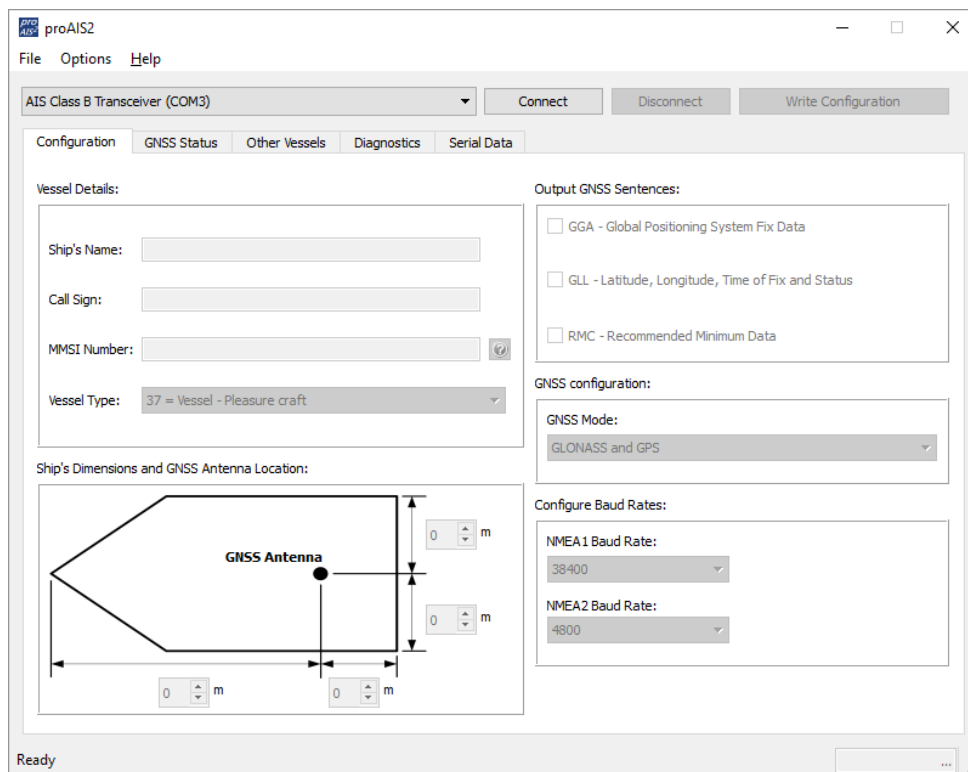

1. Enter Vessel Name, Call Sign and MMSI
2. Enter vessel dimensions and location of GPS antenna to the nearest metre.
3. Select the most appropriate vessel type.

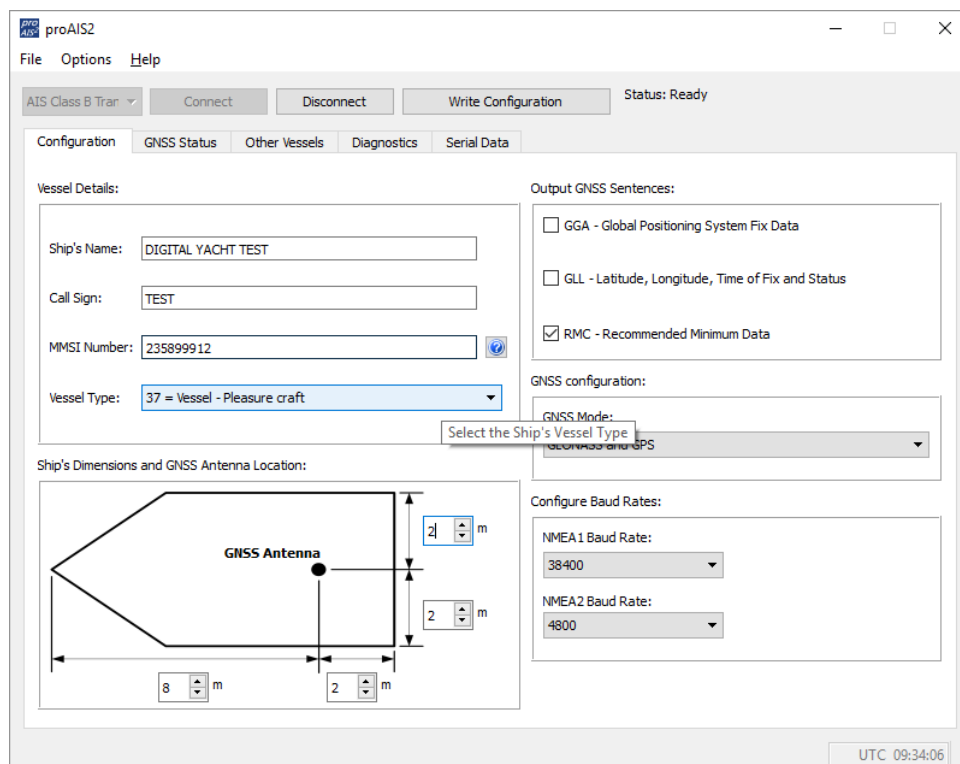

4. Click "Write Configuration" to save the data to the AIT1500N2K
5. Read the warning message carefully and proceed only if the MMSI number is correct.
6. If you are configuring a new unit with a new MMSI number then a warning message will be displayed

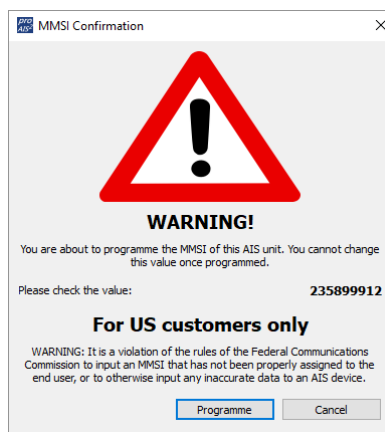

7. Read the warning message carefully and proceed only if the MMSI number is correct.
8. Should you make a mistake or need to change anything in the future, all configurations and settings, except the MMSI, can be changed by running proAIS2 and following this procedure again
9. Configuration of the AIS Class B+ Transponder is now complete

***Note:** *For security reasons the MMSI can only be programmed once. Make sure you enter the correct number and double check when ProAIS2 warns you regarding MMSI programming. The MMSI can only be changed by returning the unit to your dealer.*



5. Operation

Once installed and configured correct operation of the AIS transponder should be verified as follows:

1. Check that at least one of the LED's on the front of the unit is illuminated. If the red 'Error' LED is illuminated please refer to the troubleshooting section in the AIT1500N2K User Manual.
2. Check that the unit has a good GPS lock. If the GPS is locked the Latitude and Longitude will be displayed on the "GPS Status" tab in proAIS2 along with a number of green bars in the signal strength graph.
3. If the unit does not have GPS fix within a few minutes check your GPS antenna has a clear view of the sky, is to the correct specification and that the GPS antenna cable is connected.
4. Check that the Green 'Power' LED on the front of the unit illuminates. This will not happen until the unit has GPS fix and has transmitted its first position report. Please allow up to 5 minutes for this to occur. **If the Green LED is illuminated you have successfully installed and configured the unit.** The proAIS2 application can be closed and the PC disconnected from the unit. The unit requires only a power supply to operate.
5. If you are in an area with other AIS equipped vessels you can check the "Other vessels" tab in ProAIS2 to view position reports received from other ships.

6. Troubleshooting

If the green LED is not illuminated after around 5 minutes then please check the following:

1. Is the MMSI number programmed?
Check the "Diagnostics" tab in proAIS2. If there is a red cross next to the "AIS Transceiver MMSI Valid" item then you have not correctly configured the MMSI.
2. Does the unit have a GPS position fix?
Check the "Diagnostics" tab in proAIS2. If there is a red cross next to the "GPS position fix" item then the unit does not have GPS fix. Check your GPS antenna and connections.
3. Is the unit reporting any alarms?
Check the "Active alarms" area in the "Diagnostics" tab of ProAIS2 & refer to the troubleshooting guide at the back of the ProAIS2 user guide.
4. Is there an external power connection?
When connected to a computer via USB, the AIT1500N2K can take enough power from the USB port to work as an AIS receiver but not as a Class B transponder. Occasionally if a fault occurs in the boat's wiring, a fuse blows or the circuit breaker trips, then the AIT1500N2K will lose external power and only have the USB power. In these circumstances, the AIT1500N2K will receive AIS targets but not transmit its own position and the Red and Yellow LEDs will be lit.

For more troubleshooting information on the AIT1500N2K transponder please consult Tech Note 00036-2012 in the Support section of www.digityachtamerica.com